

Modeling the Spread of Antimicrobial Resistance: Concepts, Data and Predictions

Heinrich zu Dohna

Rockefeller University
Laboratory of Populations

Outline

- Why model?
- Basic components of transmission models
- Adding complexity: biological processes
- Adding complexity: transmission structure
- Results
- Future directions

Why model dynamics of antimicrobial resistance?

- Antimicrobial resistance occurs in many commensals
- Complete eradication of commensals is unfeasible
- How to use existing antibiotics is as important as finding new ones
- Requires understanding of dynamics of transmission and evolution of resistance

Modeling questions

- Is endogenous colonization or transmission more important for the spread of antimicrobial resistance?
- How to best combine different antibiotics?
- What is the most efficient way to minimize spread?

Basic transmission model

Population boundary (e.g. ward, hospital)



Basic transmission model

Population boundary (e.g. ward, hospital)

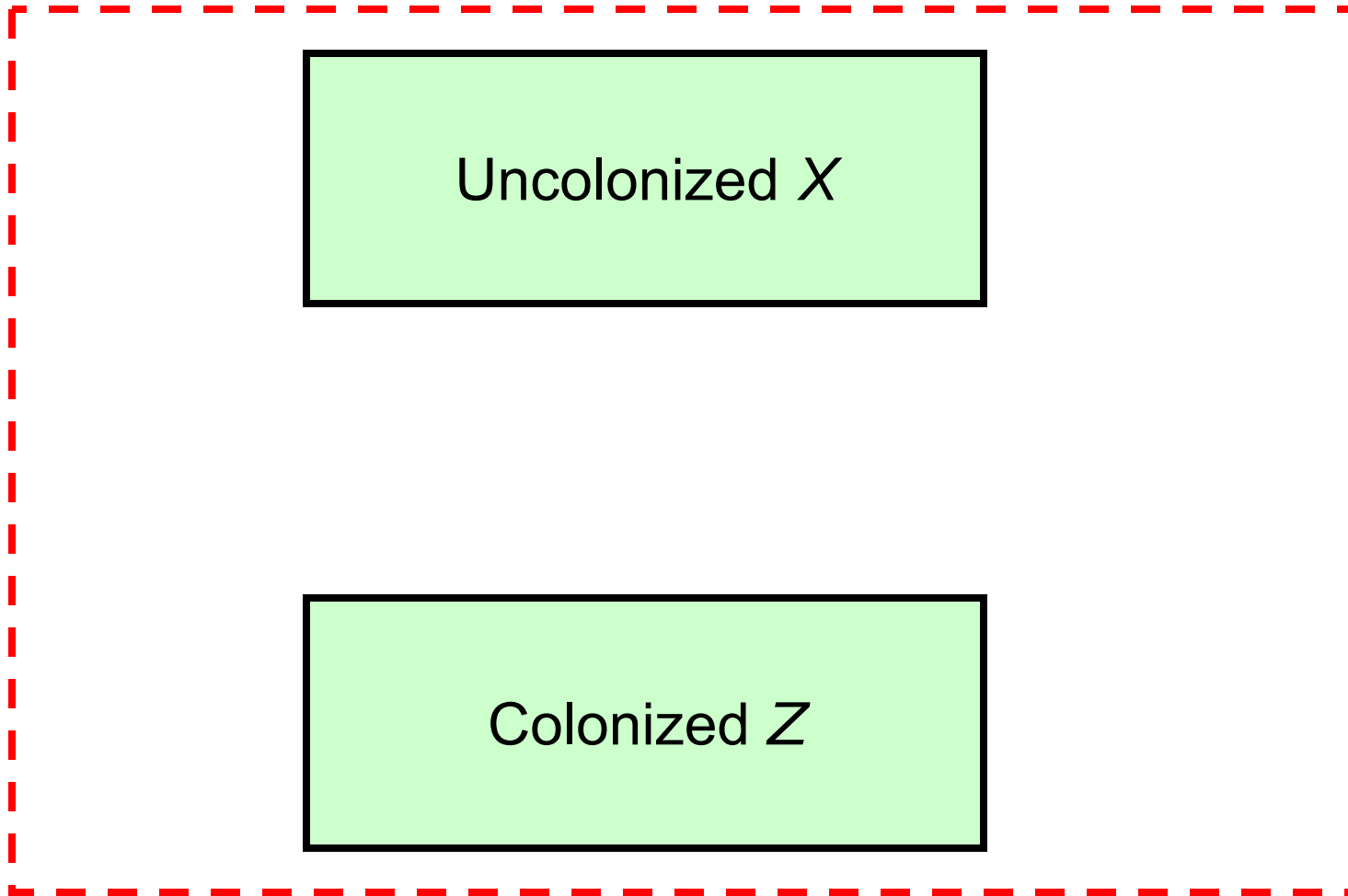

Basic transmission model

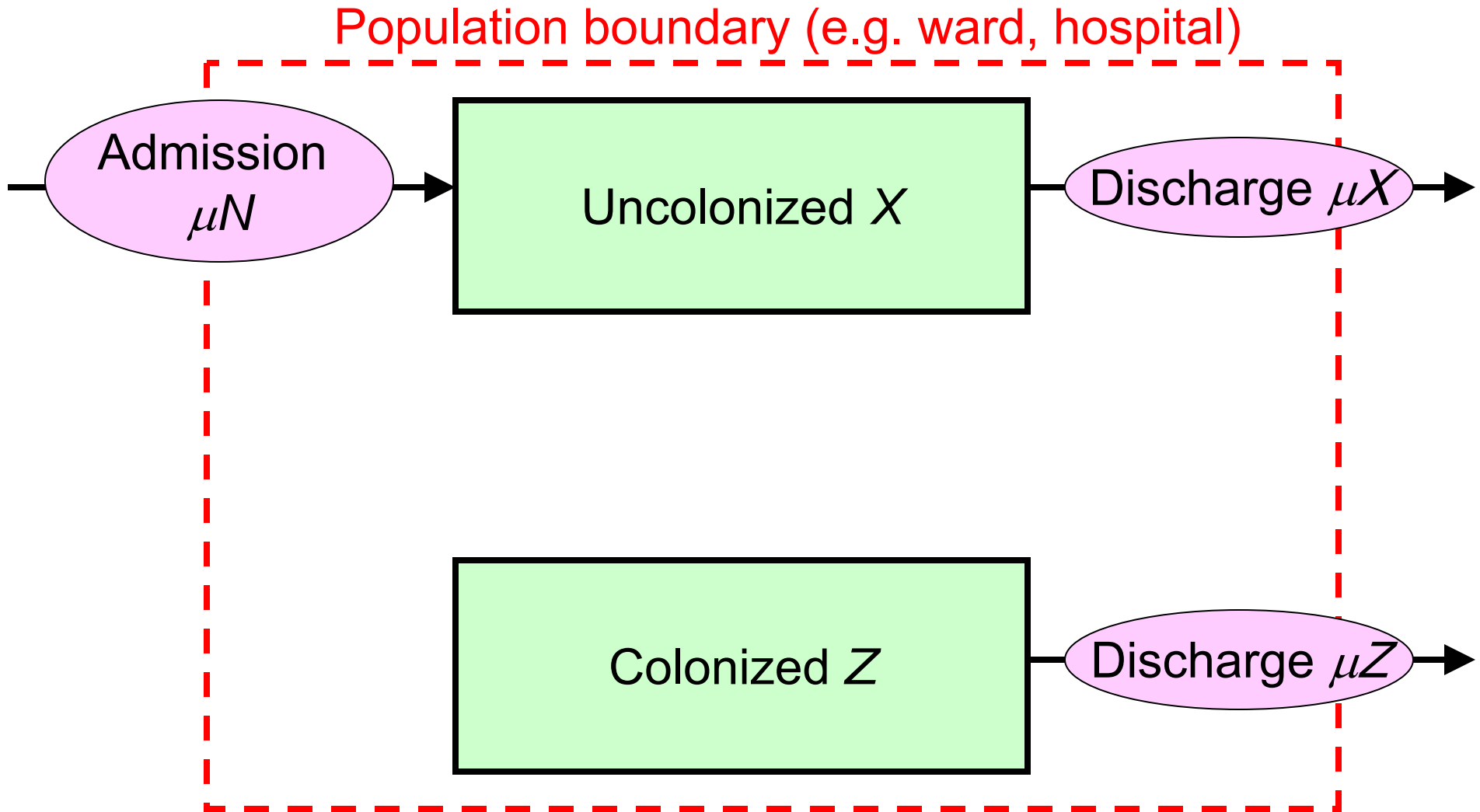

Basic transmission model

Population boundary (e.g. ward, hospital)

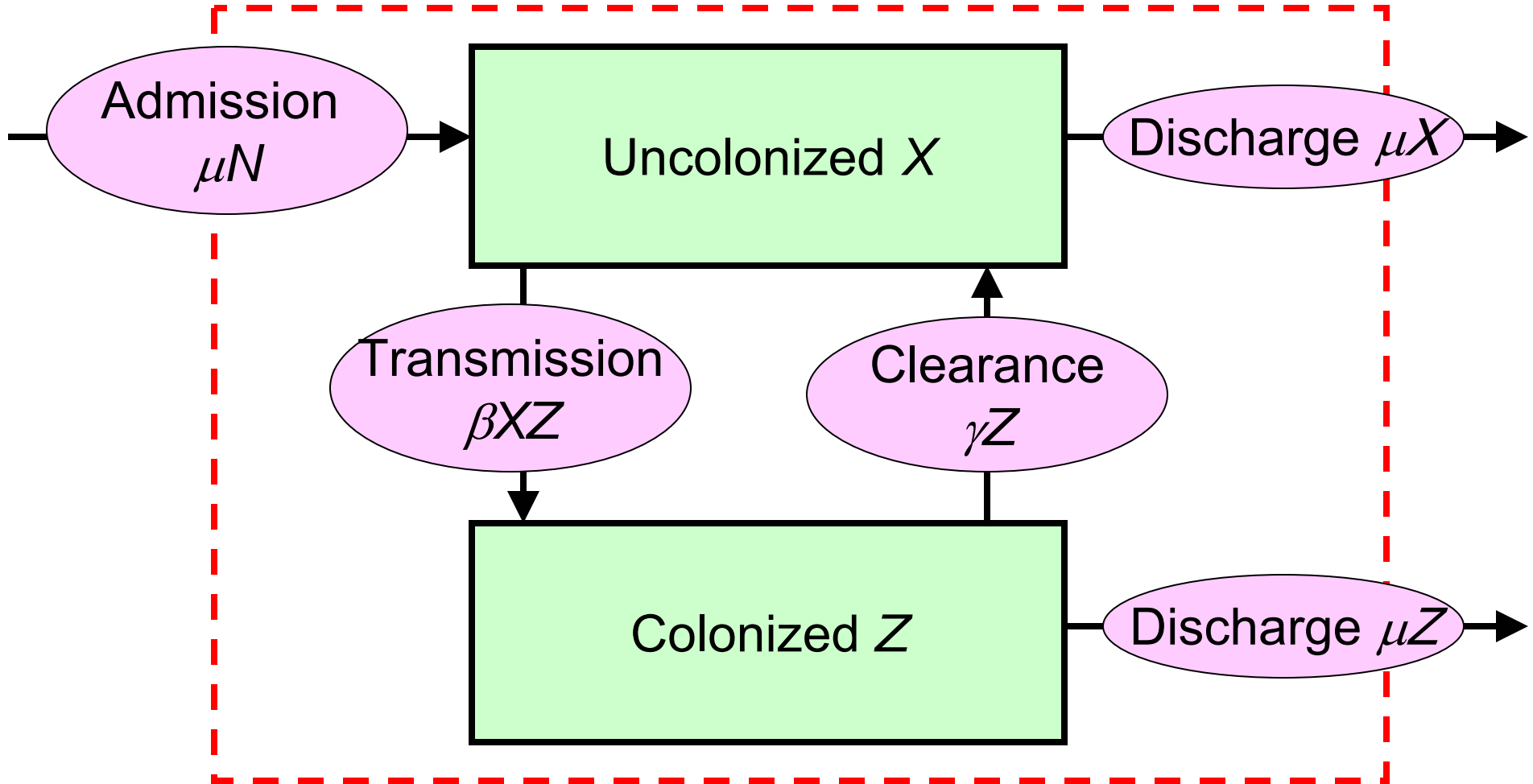

The concept of R_0

Population boundary (e.g. ward, hospital)

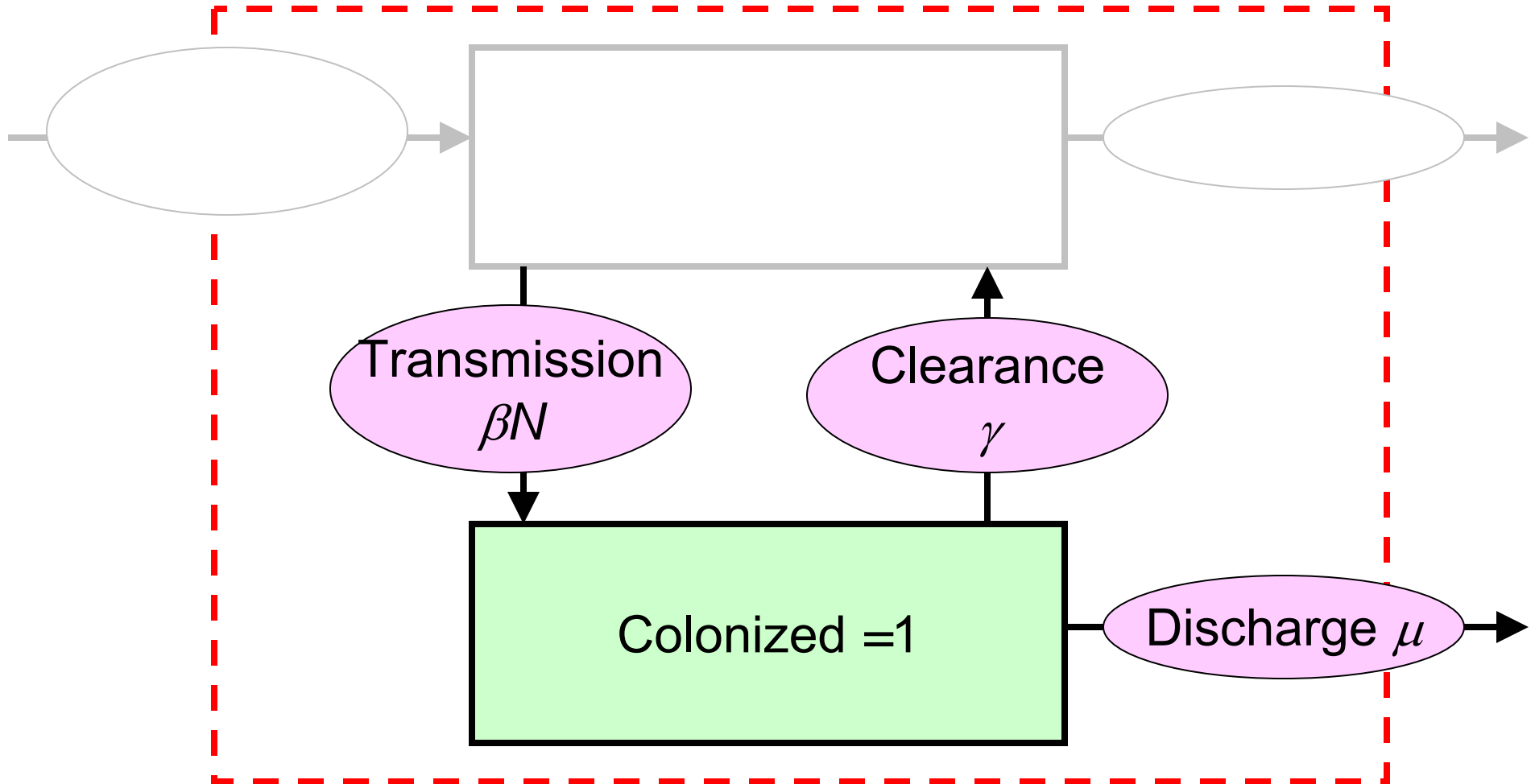

The concept of R_0

$$\frac{\beta \cdot N}{\mu + \gamma} \geq 1 \quad \rightarrow \quad \text{Colonization can spread}$$

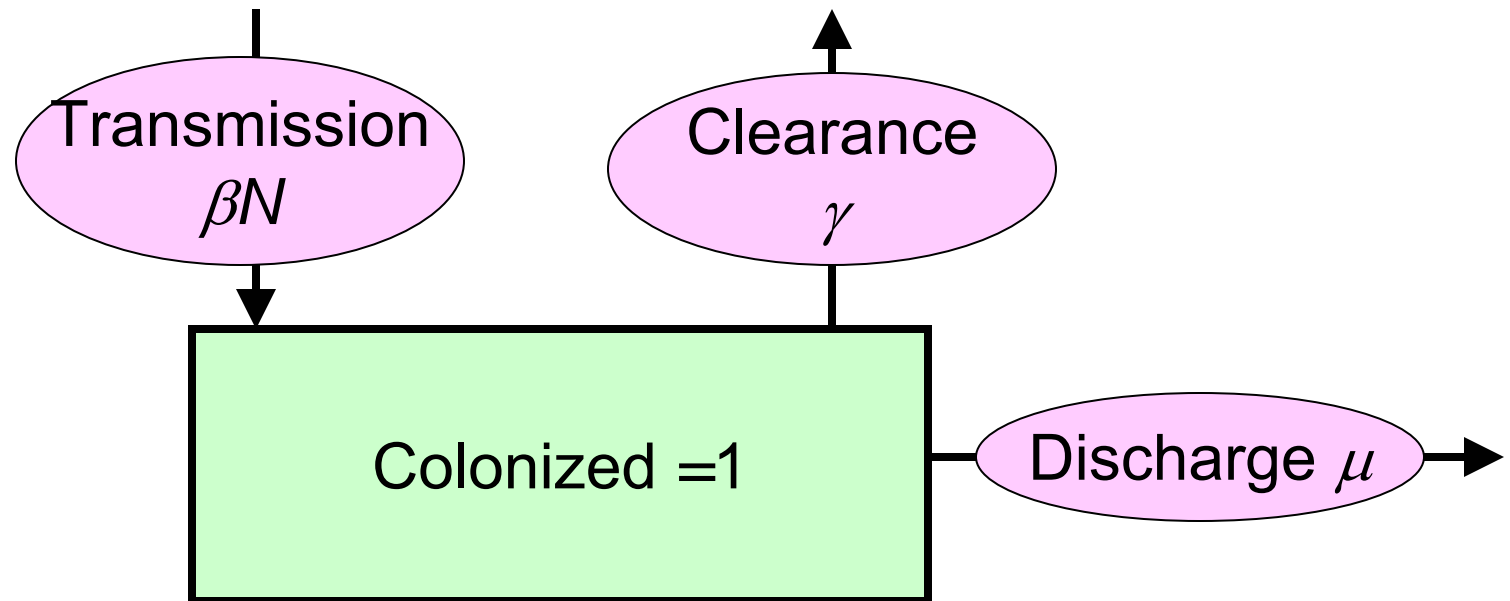

Results of transmission models

- Dynamics
- Equilibria
- R_0

Extensions of basic model

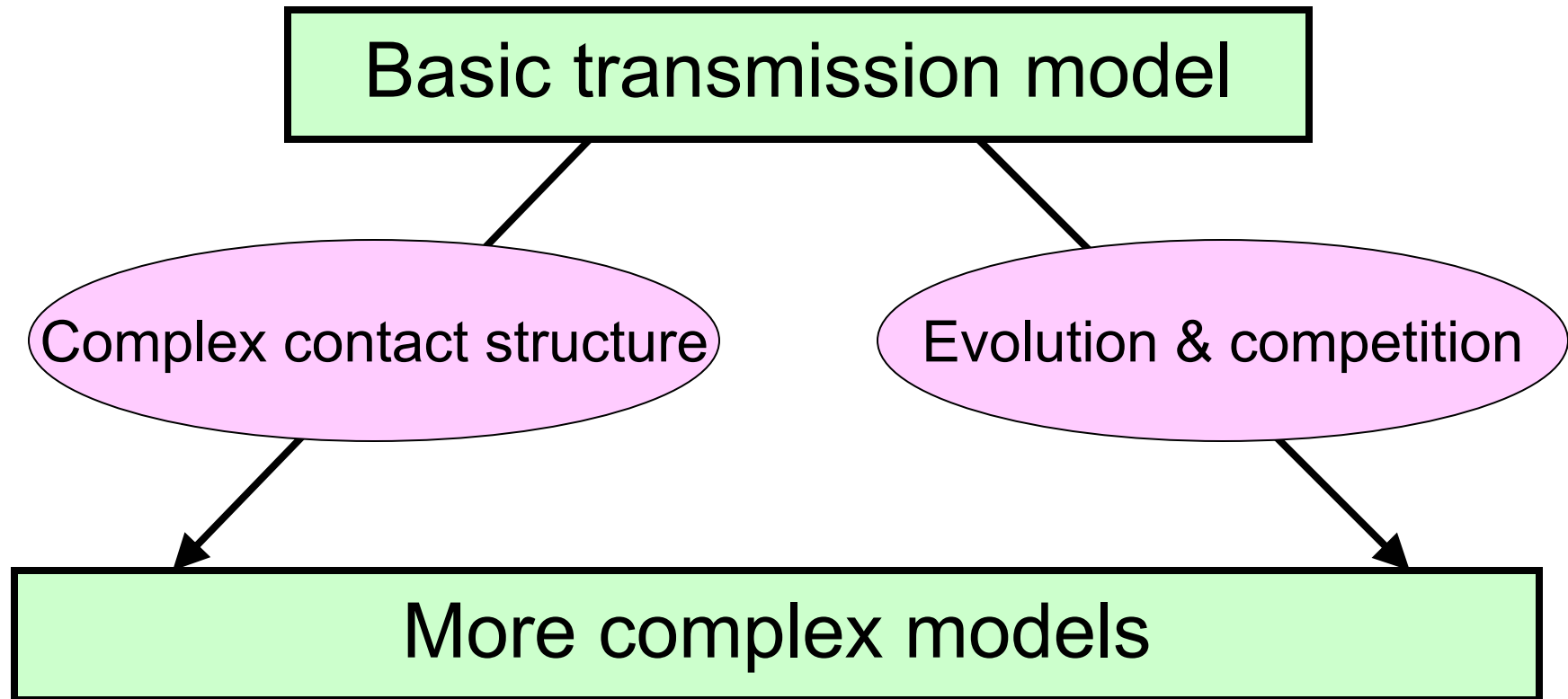

Extensions of basic model

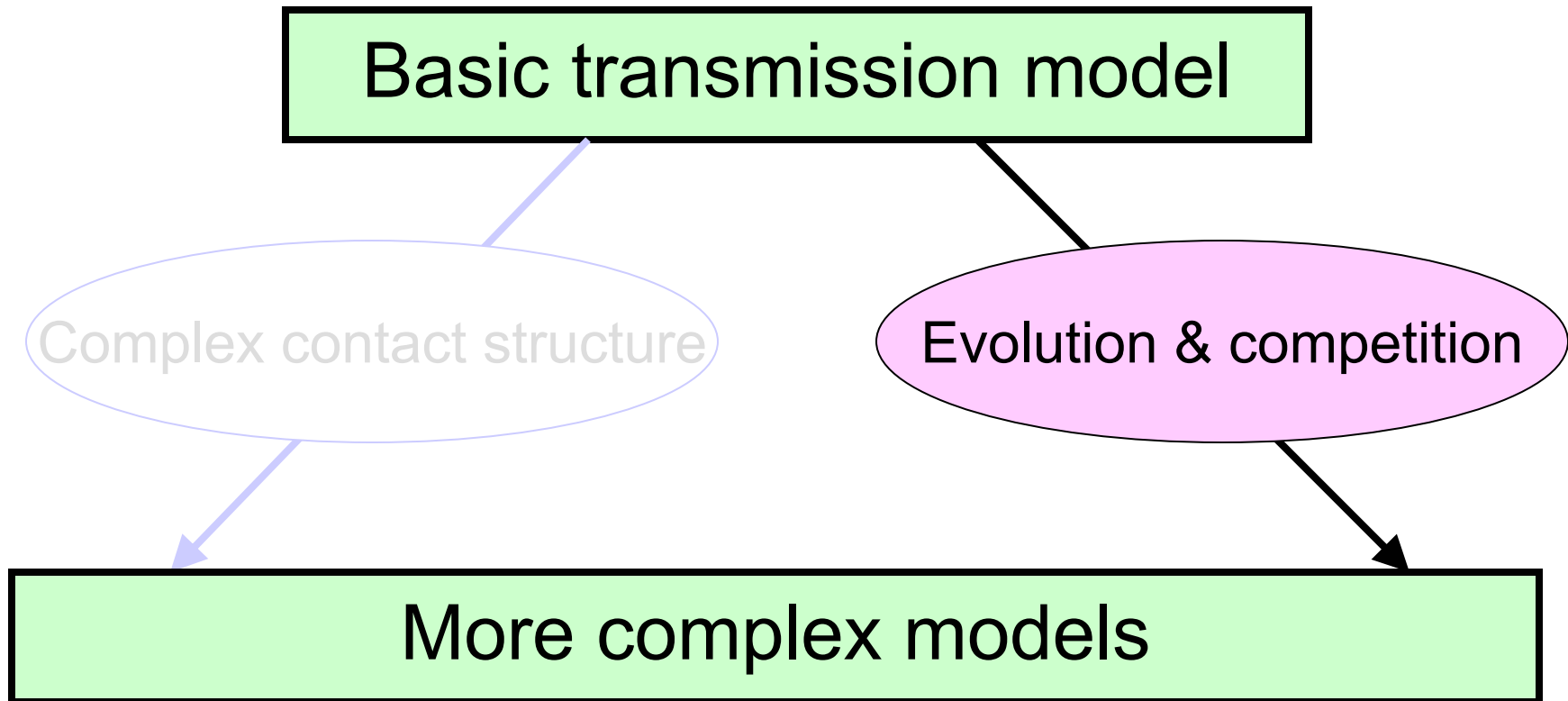

Competition & Evolution

Uncolonized x

Sensitive y

Resistant z

Competition & Evolution

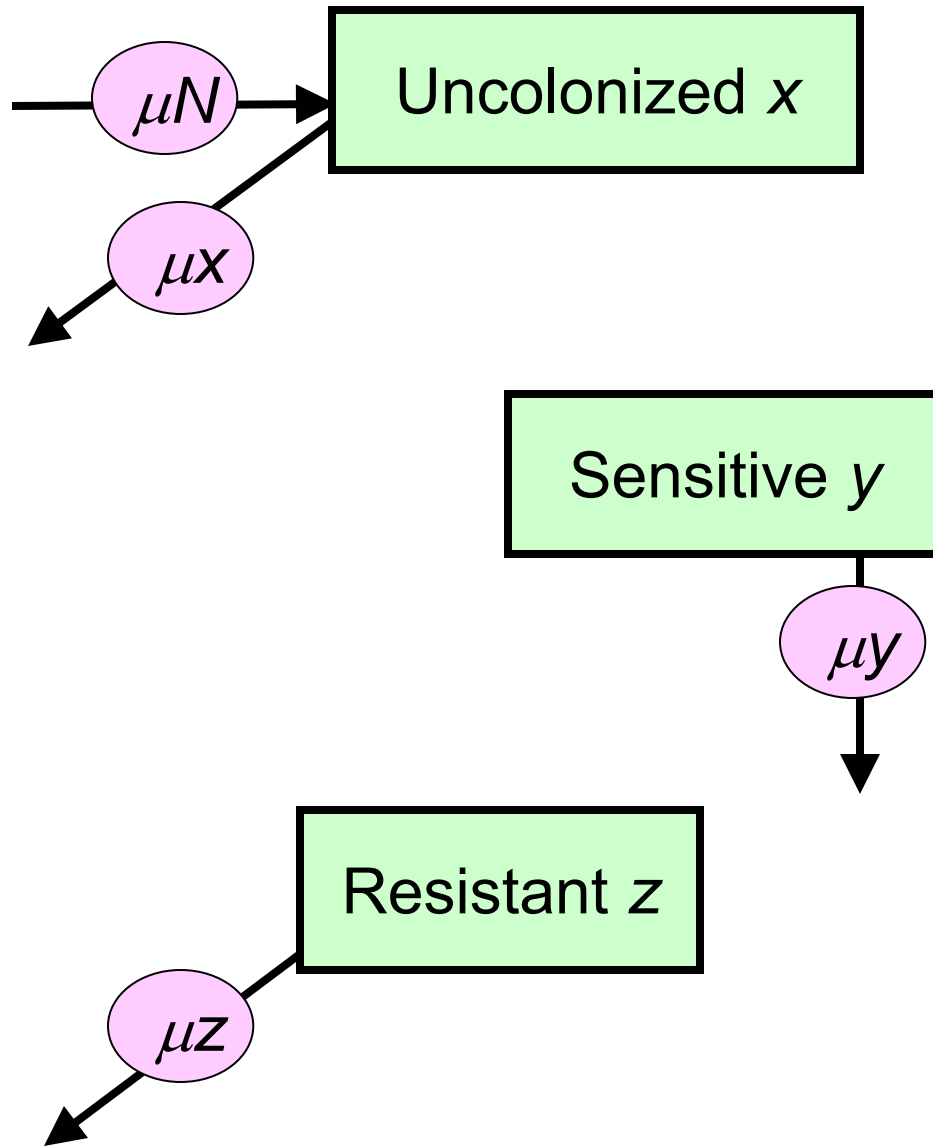

Competition & Evolution

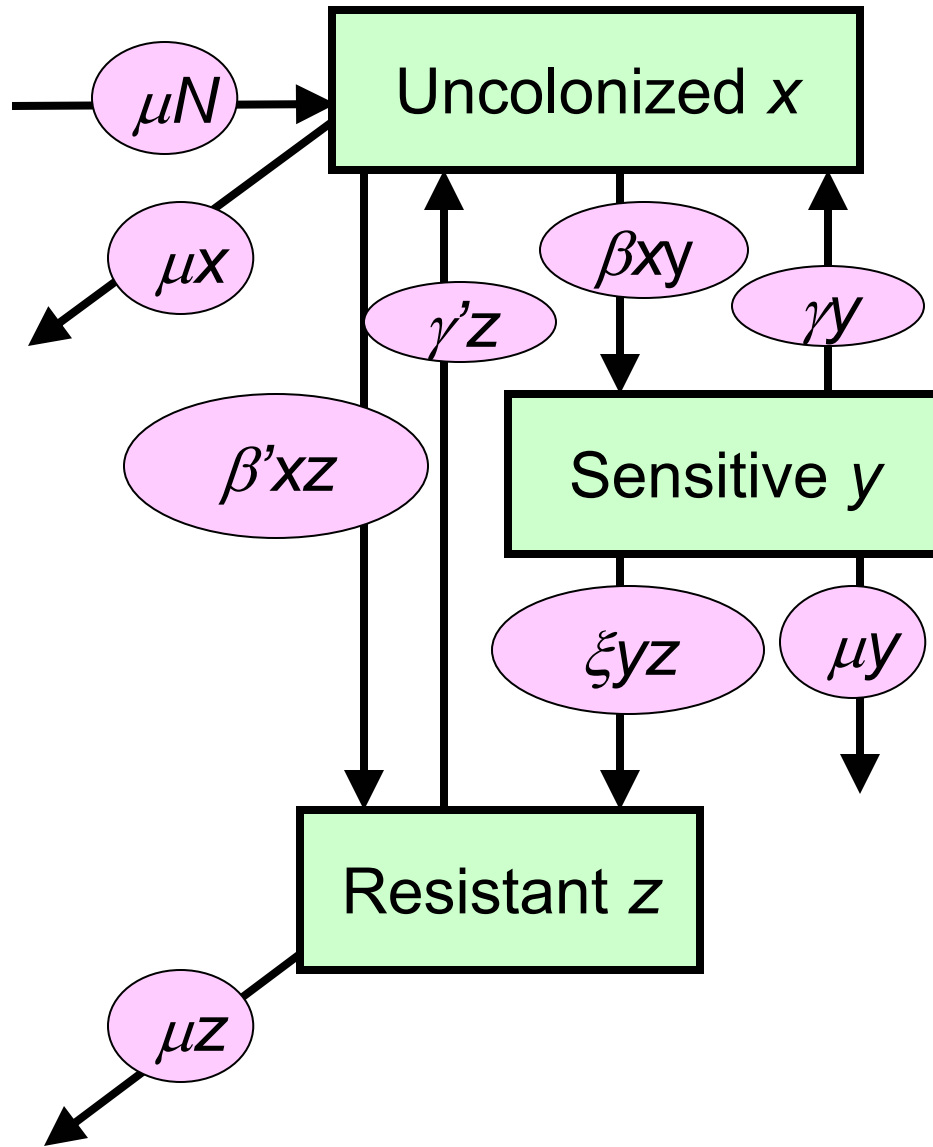

Competition & Evolution

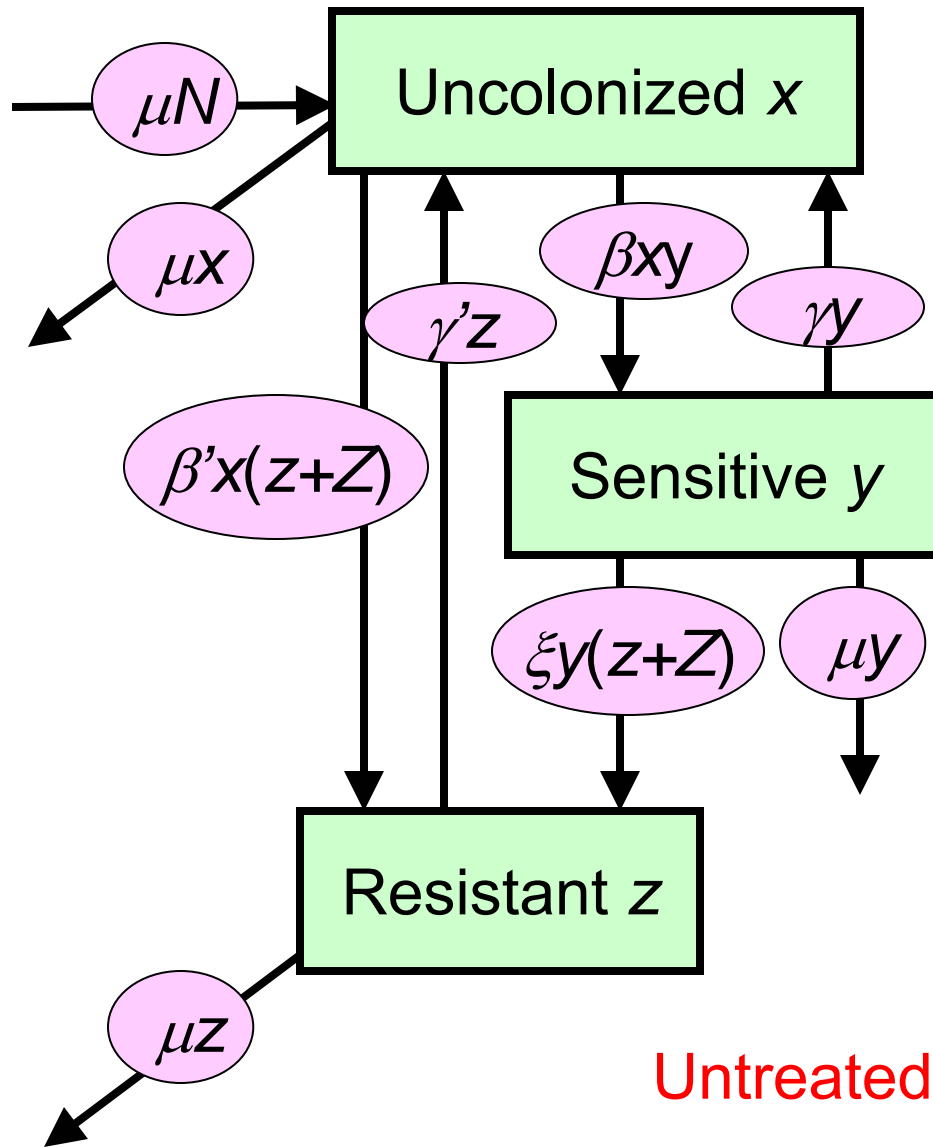

Untreated

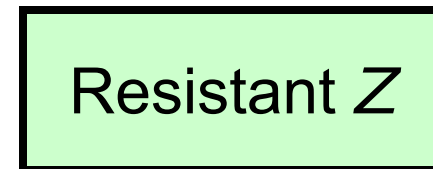
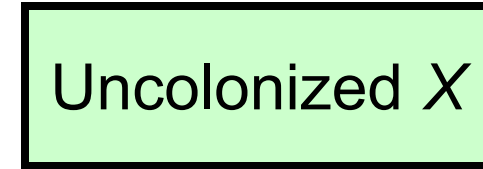

Treated

Austin et al. 1997

Competition & Evolution

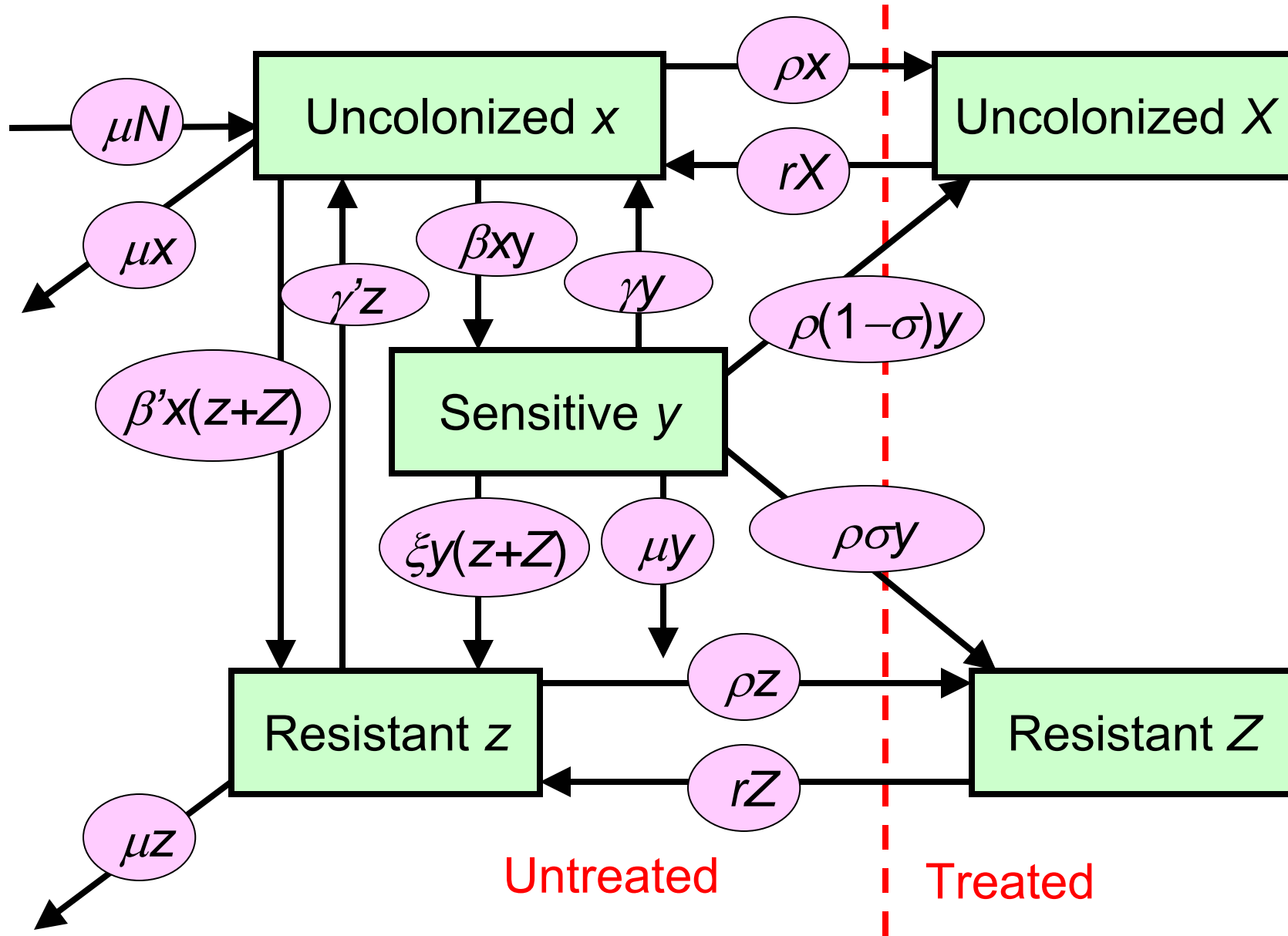

Competition & Evolution

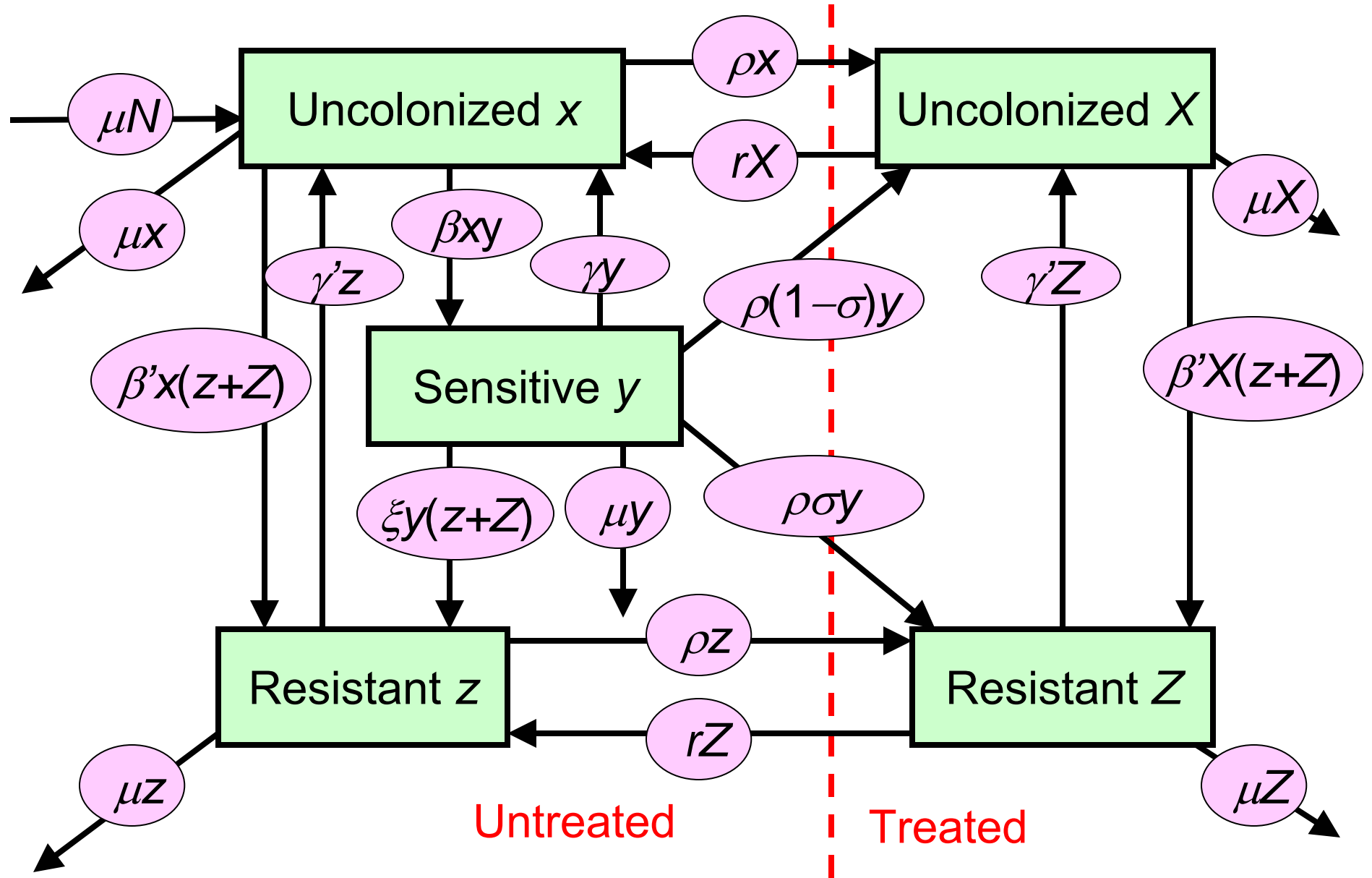

Austin et al. 1997

Qualitative predictions

- Conditions for threshold treatment rate ρ below which resistant strains die out
- Simultaneous use of different antibiotics better than sequential use
- Odds ratio not indicative of the population level effect of antibiotics
- Reducing transmission reduces resistant but not sensitive colonization

Quantitative predictions

- Require quantitative parameter estimates
→ Simplified model

Simplified model

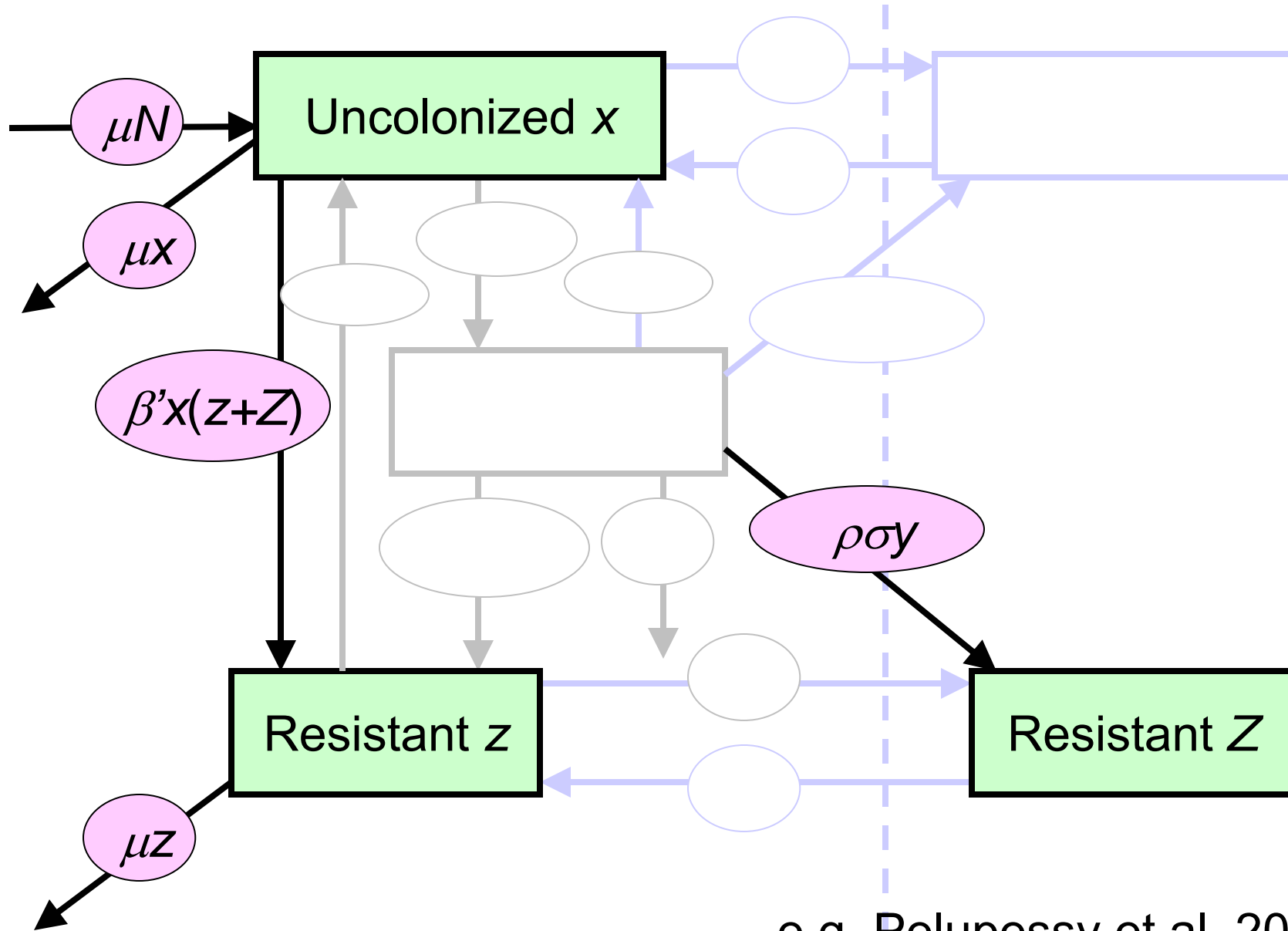

e.g. Pelupessy et al. 2002

Estimates of β

Pathogen	Method	Data	Value	Citation
MRSA	β chosen to achieve specified R_0	none	-	Cooper et al. 2004
MRSA	Endemic curve	Prevalence in USA, UK	-	Bootsma et al. 2006
MRSA VRE	Hidden Markov model	Infection incidence ICU, USA	.33/day .26/day	Cooper & Lipsitch 2004
VRE <i>P. aeruginosa</i>	Markov model	Screening in ICU (Netherlands?)	.09/day .065/day	Pelupessy et al. 2002
VRE	Mean prevalence	ICU Chicago	0.08/day 0.55/day	Austin et al. 1999

Extensions of basic model

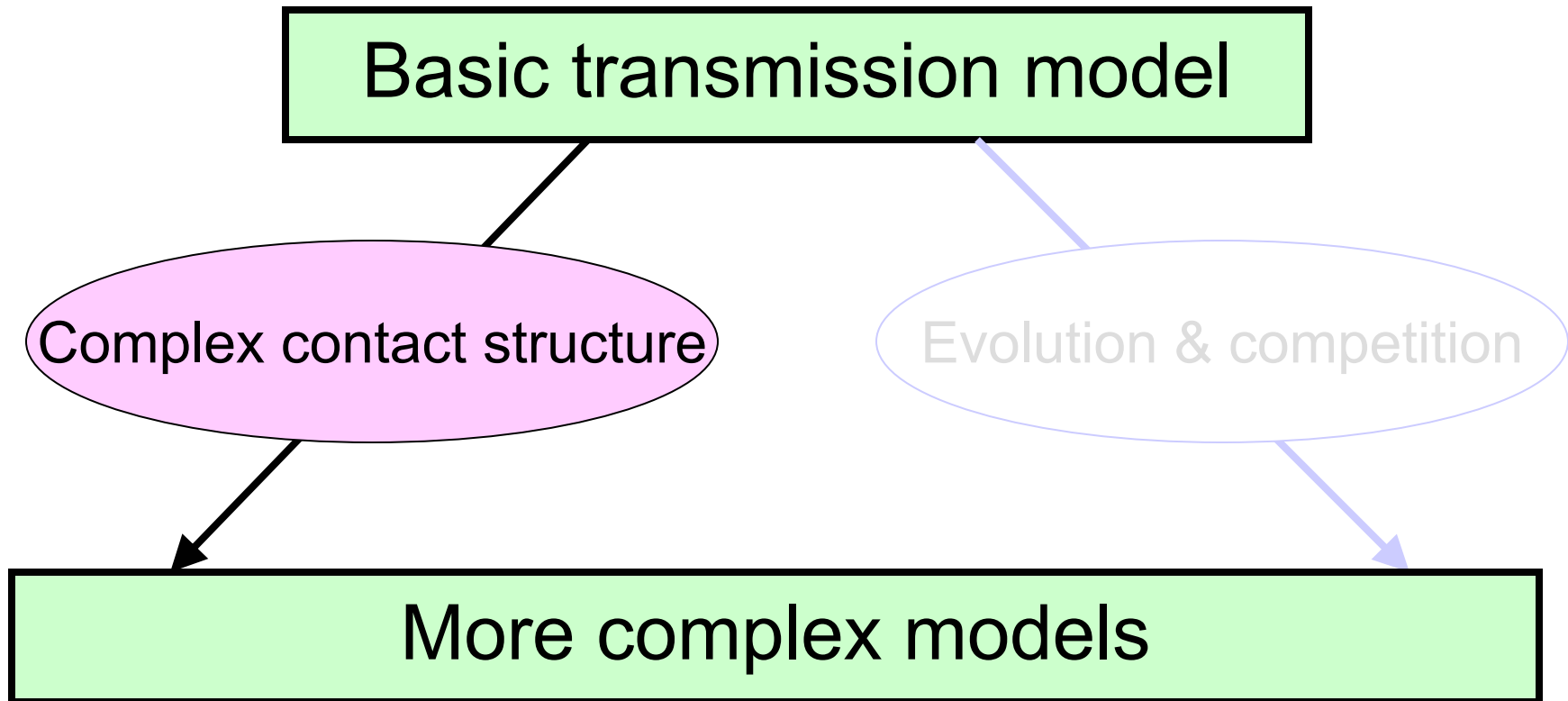

More realistic contact structure I

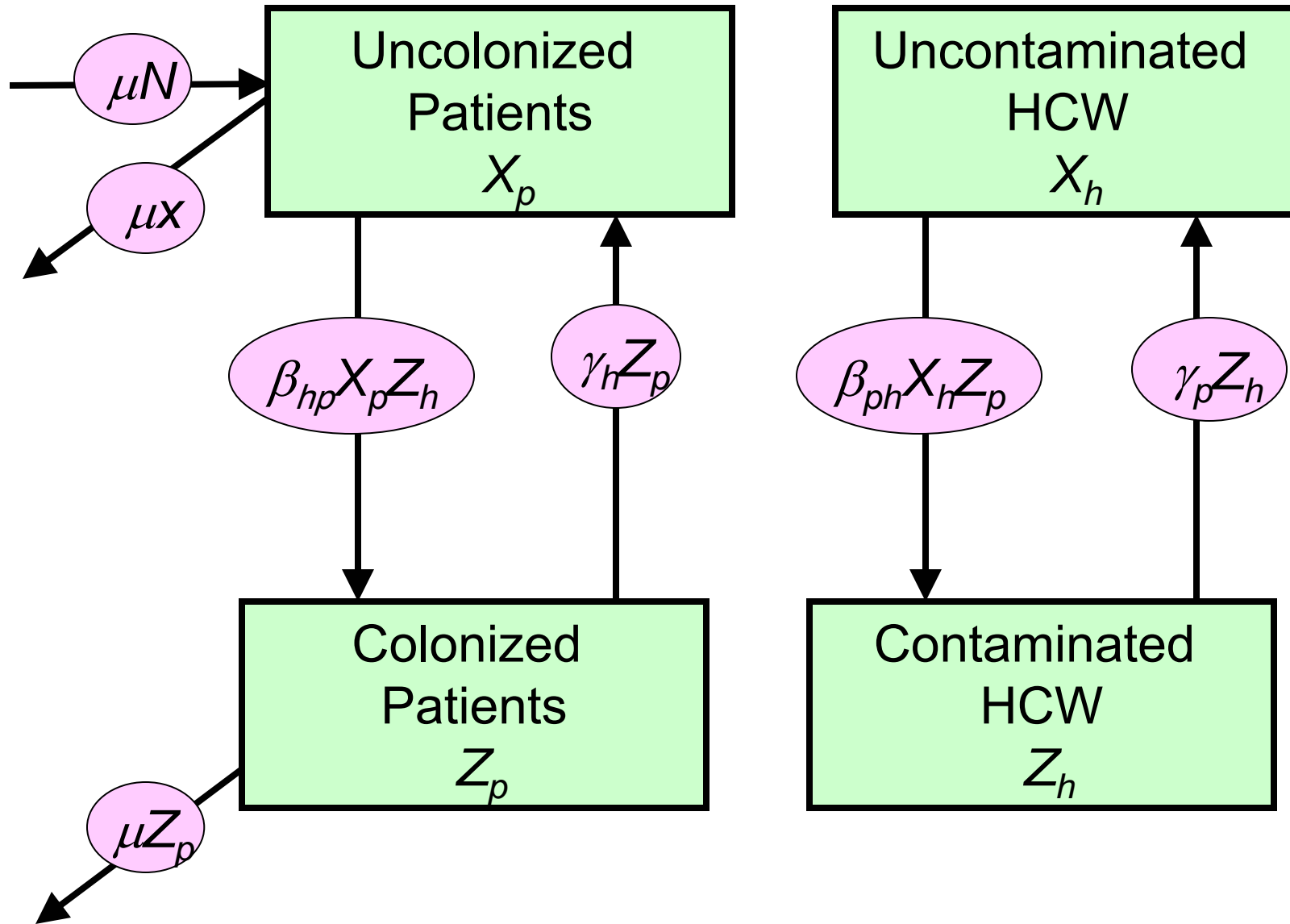

More realistic contact structure II

- Within and between ward transmission
- R_0 for entire population (re-admissions)
- Variation among individuals in transmission

Core transmission model

Ward

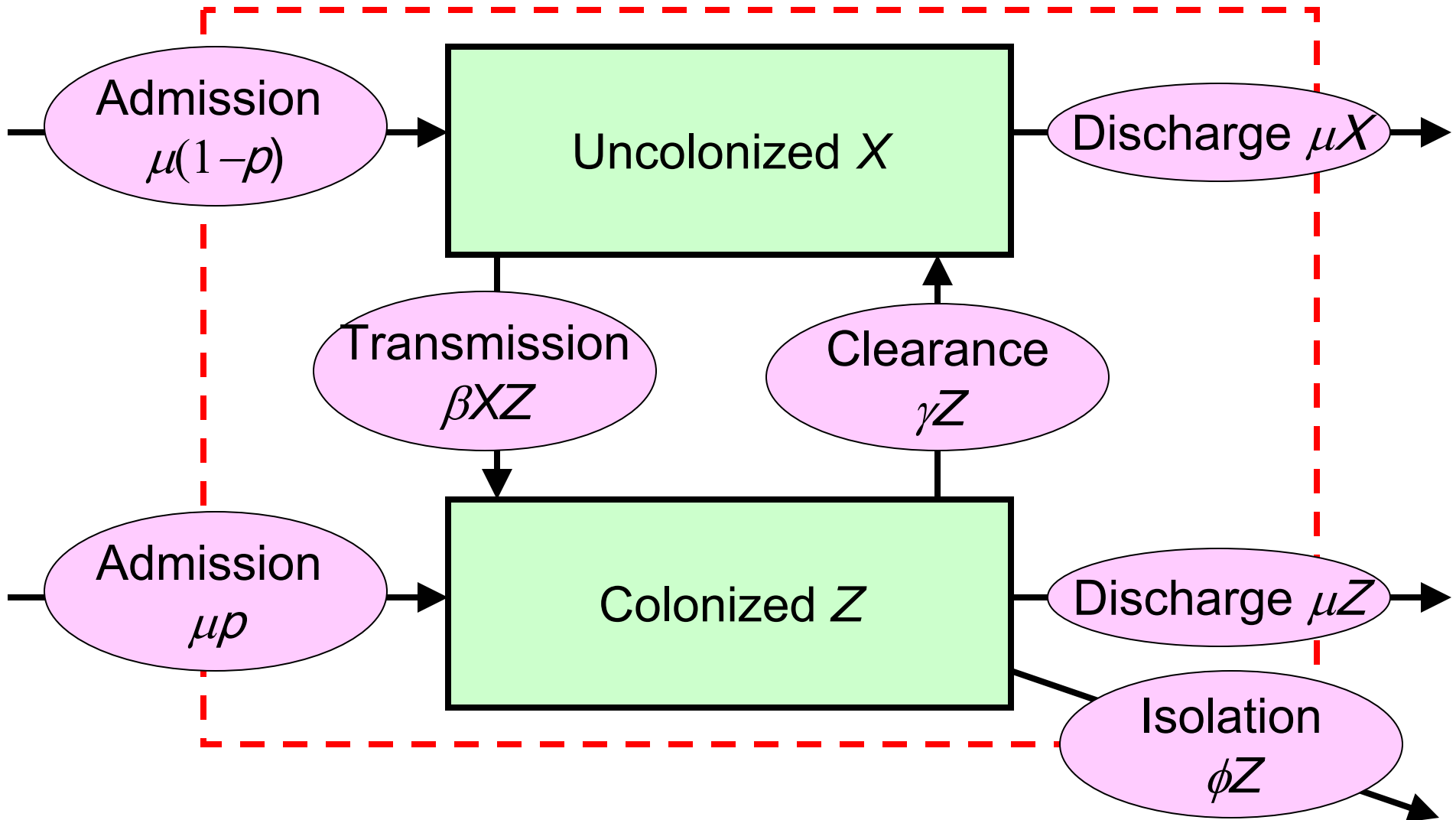

Results

- Effect of HCW depends on model structure
- Detection of colonization crucial for isolation rate
- Hospital $R_0 \leq$ global R_0
- Efficient detection and removal can lead to global $R_0 < 1$
- Coordination among hospitals crucial

Overview of different models

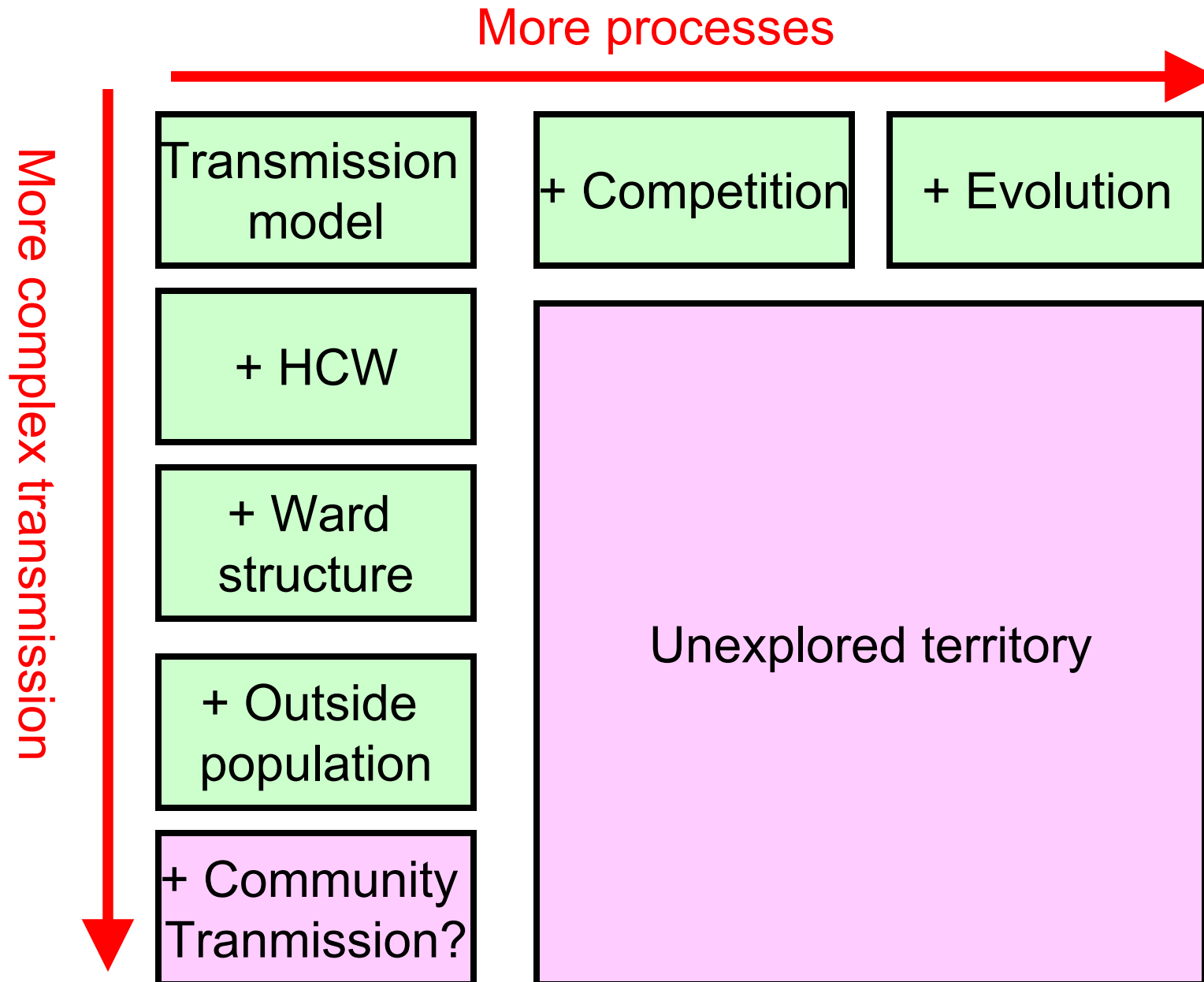

Future directions

- Parameter estimates for competition & evolution
- Transmission beyond βXZ
- Community transmission